

IMPRINTING AND APPLYING LABELS

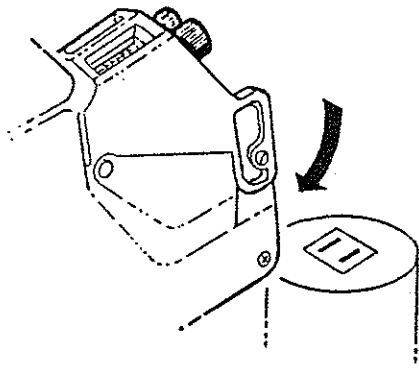

FIGURE 8

1 Squeeze and release handle to imprint and feed out a label which will appear at the label application area.

2 Place the lower front edge of the labeller on the product and apply the label with a wiping motion.

IMPORTANT: SQUEEZE THE HANDLE WITH JUST ENOUGH PRESSURE TO CAUSE THE LABELLER TO IMPRINT AND DISPENSE A LABEL, OVER SQUEEZING MAY CAUSE HEAVY OR UNCLEAR PRINT.

SETTING PRINT

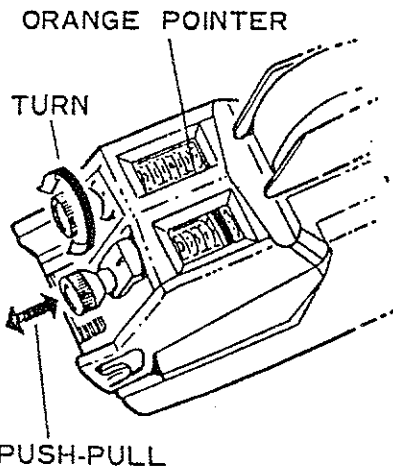

FIGURE 9

1 To set a desired character, align the orange pointer with a desired print band by moving indexing knob in or out. Turn indexing knob in either direction until the desired character with the yellow background* portion of the band is visible in the window. Repeat as necessary.

2 To avoid damage to the print bands, always push the indexing knob all the way in, after the information is set.

3 When dialling ensure you are reading yellow banks* only. There should not be any black bands visible.

* On single line machines the background is black and the numbers yellow.

CHANGING INK ROLLER

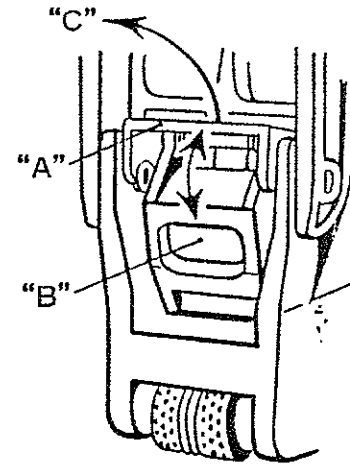

FIGURE 10

1 Squeeze the ink roller lever (see Figure 10 "A") and the ink roller assembly ("B") together.

2 Lift the ink roller assembly up and out of the labeller (See Figure 10 "C").

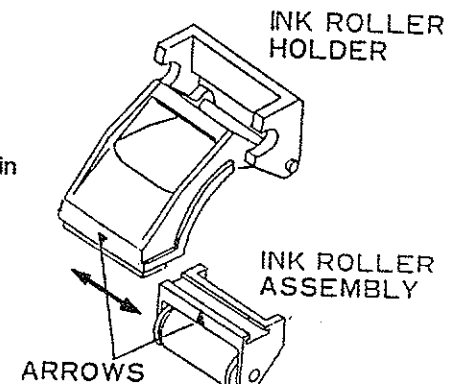

FIGURE 11

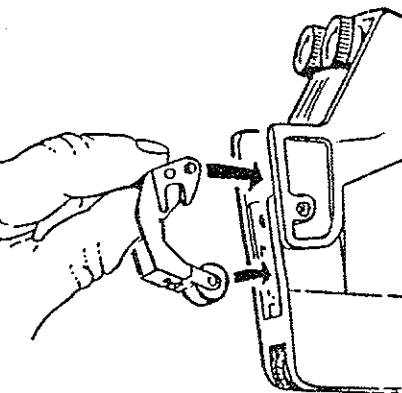

FIGURE 12

3 Hold the ink roller assembly firmly in hand, while sliding ink roller holder either left or right to separate parts off track (Figure 11).

4 Slide new ink roller on track of holder until arrows line up (Figure 11).

5 Squeeze ink roller lever and ink roller assembly together and insert in front of labeller.

6 Only the ink roller should be thrown away. Not the holder.